

Company:	Contact:
Email:	Address:
City:	State:
Post Code:	Country:
Phone Number:	Fax Number:

Cyber33 forms;

Anti-Spam; Please retype the words above, into the security field below.
nb. a correct answer is required to submit this form

1. Machine No.	2. Frame No.	3. Manufacturer
4. Rated Output (HP / kW)	5. Rated Voltage (V)	6. Rated Current (A)
7. Rated Speed (rpm)	8. Class Of Insulation	9. Core Diameter
10. Core Length	11. Number Of Slots	12. Slot Depth
13. Coil Space	14. Slot Width Top	15. Slot Width Bottom
16. Finger Height	17. Skewing Of Slots	18. Skewing Direction (R or L)
19. Number Of Commutator Bars	20. Riser Diameter	21. Commutator Diameter
22. Riser Width	23. Number Of Turns Per Coil	24. Number Of Wires In Parallel
25. Bare Wire Width	26. Bare Wire Thickness	27. Insulated Wire Width
28. Insulated Wire Thickness	29. Wire Thickness In Commutator	30. Coil Width In Slot
31. Coil Width Outside Slot	32. Straight Length Of Coil Side	33. Rear Extension
34. Distance Between Coil And Riser	35. Leads Tinned Or Not	36. Single Or Double Knuckle
37. Minimum Winding Diameter	38. Front Extension	39. Coil Span From '1' To 'N'
40. CL Falls On Bar No. '1' Or Mica	41. Bar Number "Z"	

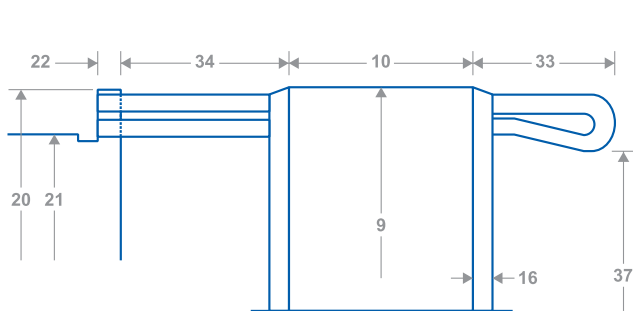

36A

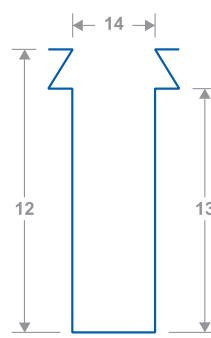

SLOT

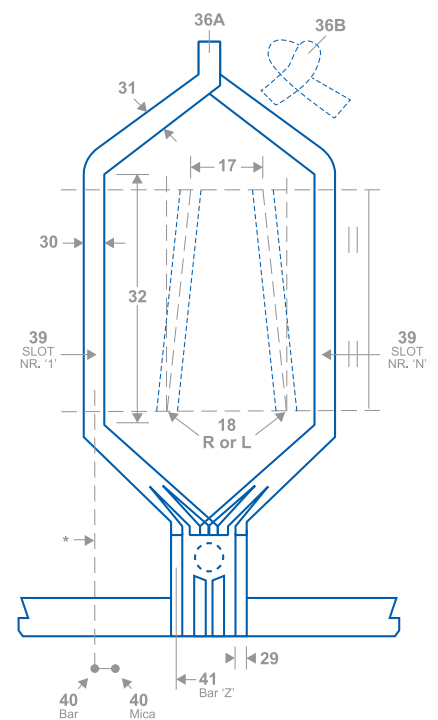

36B

COIL SLOT SIDE CROSS SECTION

* CL (CENTRELINE) OF SLOT PARALLEL WITH CL OF SHAFT